

**Notice of Filing of Certification for Beneficiary Status Under the Environmental Mitigation
Trust Agreement for the Mohegan Tribe of Indians of Connecticut**

December 27, 2017

APPENDIX D-3
Certification for Beneficiary Status
Under Environmental Mitigation Trust Agreement

APPENDIX D-3

**CERTIFICATION FOR BENEFICIARY STATUS
UNDER ENVIRONMENTAL MITIGATION TRUST AGREEMENT**

1. Identity of Lead Agency

Mohegan Tribe of Indians of Connecticut (MTIC) (“Beneficiary”), by and through the Office of the Governor (or the analogous Chief Executive) of the Indian Tribe on whose behalf the Certification Form is submitted: (i) hereby identifies Mohegan Environmental Protection Department (MEPD) (“Lead Agency”) as the Lead Agency for purposes of the Beneficiary’s participation in the Environmental Mitigation Trust (“Trust”) as a Beneficiary; and (ii) hereby certifies that the Lead Agency has the delegated authority to act on behalf of and legally bind the Beneficiary for purposes of the Trust.

BENEFICIARY’S LEAD AGENCY CONTACT INFORMATION:

Contact:	Jean E. McInnis, Mohegan Environmental Protection Administrator
Address:	13 Crow Hill Road, Uncasville, CT 06382
Phone:	860-862-6112
Fax:	860-862-6129
Email:	jmclinnis@moheganmail.com

2. Submission to Jurisdiction

The Beneficiary expressly consents to the jurisdiction of the U.S. District Court for the Northern District of California for all matters concerning the interpretation or performance of, or any disputes arising under, the Trust and the Environmental Mitigation Trust Agreement (“Trust Agreement”). The Beneficiary’s agreement to federal jurisdiction for this purpose shall not be construed as consent to federal court jurisdiction for any other purpose.

3. Agreement to be Bound by the Trust Agreement and Consent to Trustee Authority

The Beneficiary agrees, without limitation, to be bound by the terms of the Trust Agreement, including the allocations of the Trust Assets set forth in Appendix D-1 and Appendix D-1A to the Trust Agreement, as such allocation may be adjusted in accordance with the Trust Agreement. The Beneficiary further agrees that the Trustee has the authorities set forth in the Trust Agreement, including, but not limited to, the authority: (i) to approve, deny, request modifications, or request further information related to any request for funds pursuant to the Trust Agreement; and (ii) to implement the Trust Agreement in accordance with its terms.

4. Certification of Legal Authority

The Beneficiary certifies that: (i) it has the authority to sign and be bound by this Certification Form; (ii) the Beneficiary’s laws do not prohibit it from being a Trust Beneficiary; and (iii) prior

to requesting any funds from the Trust, the Beneficiary has obtained full legal authority to receive and/or direct payments of such funds. If the Beneficiary fails to demonstrate that it has obtained such legal authority, it shall not qualify as a Beneficiary under the Trust Agreement until it has obtained such legal authority.

5. Certification of Legal Compliance and Disposition of Unused Funds

The Beneficiary certifies and agrees that, in connection with all actions related to the Trust and the Trust Agreement, the Beneficiary has followed and will follow all applicable law and will assume full responsibility for its decisions in that regard. The Beneficiary further certifies that all funds received on account of any Eligible Mitigation Action request that are not used for the Eligible Mitigation Action shall be returned to the Trust for credit to the Tribal Allocation Subaccount.

6. Waiver of Claims for Injunctive Relief under Environmental or Common Laws

Upon becoming a Beneficiary, the Beneficiary, on behalf of itself and all of its agencies, departments, offices, and divisions, hereby expressly waives, in favor of the parties (including the Settling Defendants) to the Partial Consent Decree (Dkt. No. 2103-1) and the parties (including the Defendants) to the Second Partial Consent Decree (Dkt. No. 3228-1), all claims for injunctive relief to redress environmental injury caused by the 2.0 Liter Subject Vehicles and the 3.0 Liter Subject Vehicles (jointly, "Subject Vehicles"), whether based on the environmental or common law within its jurisdiction. This waiver is binding on all agencies, departments, offices, and divisions of the Beneficiary asserting, purporting to assert, or capable of asserting such claims. This waiver does not waive, and the Beneficiary expressly reserves, its rights, if any, to seek fines or penalties. No waiver submitted by any Indian Tribe shall be effective unless and until such Indian Tribe actually receives Trust Funds.

7. Publicly Available Information

The Beneficiary certifies that it will maintain and make publicly available all documentation and records: (i) submitted by it in support of each funding request; and (ii) supporting all expenditures of Trust Funds by the Beneficiary, each until the Termination Date of the Trust pursuant to Paragraph 6.8 of the Trust Agreement, unless the laws of the Beneficiary require a longer record retention period. Together herewith, the Beneficiary attaches an explanation of: (i) the procedures by which the records may be accessed, which shall be designed to support access and limit burden for the general public; and (ii) a description of whether and the extent to which the certification in this Paragraph 7 is subject to the Beneficiary's applicable laws governing the publication of confidential business information and personally identifiable information.

8. Notice of Availability of Mitigation Action Funds

The Beneficiary certifies that, not later than 30 Days after being deemed a Beneficiary pursuant to the Trust Agreement, the Beneficiary will provide a copy of the Trust Agreement with Attachments to the U.S. Department of the Interior, the U.S. Department of Agriculture, and any

other Federal agency that has custody, control or management of land within or contiguous to the territorial boundaries of the Beneficiary and has by then notified the Beneficiary of its interest hereunder, explaining that the Beneficiary may request Eligible Mitigation Action funds for use on lands within that Federal agency's custody, control or management (including, but not limited to, Clean Air Act Class I and II areas), and setting forth the procedures by which the Beneficiary will review, consider, and make a written determination upon each such request.

9. Registration of Subject Vehicles

The Beneficiary certifies, for the benefit of the Parties (including the Settling Defendants) to the Partial Consent Decree and the Parties to the Second Partial Consent Decree (including the Defendants) and the owners from time-to-time of Subject Vehicles, that upon becoming a Beneficiary, the Beneficiary:

- (a) Shall not deny registration to any Subject Vehicle based solely on:
 - i. The presence of a defeat device or AECB covered by the resolution of claims in the Partial Consent Decree or in the Second Partial Consent Decree; or
 - ii. Emissions resulting from such a defeat device or AECB; or
 - iii. The availability of an Approved Emissions Modification, an Emissions Compliant Recall or the Buyback, Lease Termination, and Owner/Lessee Payment Program.
- (b) Shall not deny registration to any Subject Vehicle that has been modified in accordance with an Approved Emissions Modification or an Emissions Compliant Recall based solely on:
 - i. The fact that the vehicle has been modified in accordance with the Approved Emissions Modification or the Emissions Compliant Recall; or
 - ii. Emissions resulting from the modification (including, but not limited to, the anticipated emissions described in Appendix B to the Partial Consent Decree and Appendix B to the Second Partial Consent Decree); or
 - iii. Other emissions-related vehicle characteristics that result from the modification; or
 - iv. The availability of an Approved Emissions Modification, an Emissions Compliant Recall or the Buyback, Lease Termination, and Owner/Lessee Payment Program.
- (c) May identify Subject Vehicles as having been modified, or not modified, in accordance with the Approved Emissions Modification or the Emissions

Compliant Recall on the basis of VIN-specific information provided to the Beneficiary by the Defendants.

- (d) Notwithstanding the foregoing, the Beneficiary may deny registration to any Subject Vehicle on the basis that the Subject Vehicle fails to meet EPA's or the Beneficiary's failure criteria for the onboard diagnostic ("OBD") inspection; or on other grounds authorized or required under applicable federal regulations (including an approved State Implementation Plan) or under Section 209 or 177 of the Clean Air Act and not explicitly excluded in subparagraphs 9(a)-(b).

10. Reliance on Certification

The Beneficiary acknowledges that the Trustee is entitled to rely conclusively on, without further duty of inquiry, and shall be protected in relying upon, this Appendix D-3 Certification, or a subsequent communication from the Lead Agency designating new or additional authorized individuals, as setting forth the Lead Agency and the authorized individuals who may direct the Trustee with respect to all of the Beneficiary's rights and duties under the Trust Agreement. The Beneficiary and its delegated Lead Agency, including all authorized individuals, agree to comply with all security procedures, standard payment and signatory authorization protocols, as well as procedures for designating new or additional authorized individuals, as set forth by the Trustee.

FOR THE GOVERNOR (or the analogous Chief Executive):

Signature: 

Name: Kevin P. Brown
 Title: Chairman, Mohegan Tribe of Indians of CT
 Date: December 12, 2017
 Location: 13 Crow Hill Road, Uncasville, CT 06382

[FOR OTHER REQUIRED SIGNATORIES] :

Signature: _____
 Name: _____
 Title: _____
 Date: _____
 Location: _____

APPENDIX D-3 PARAGRAPH 7 CERTIFICATION SUPPLEMENT

FOR

MOHEGAN TRIBE OF INDIANS OF CONNECTICUT

The Mohegan Tribe of Indians of Connecticut shall publish on its official governmental website <https://mohegan.nsn.us/> a public notice of availability for public review of documentation and records: (i) submitted by it in support of each funding request; and (ii) supporting all expenditures of Trust Funds by the Beneficiary, each until the Termination Date of the Trust pursuant to Paragraph 6.8 of the Trust Agreement. The public notice shall instruct members of the public to contact the Chief Operating Officer of the Mohegan Tribe of Indians of Connecticut to arrange to inspect such records during normal business hours, which are Monday through Friday, 8:30 a.m. to 4:30 p.m. at the Beneficiary's business address, Mohegan Tribe of Indians of Connecticut, 13 Crow Hill Road, Uncasville CT 06382.

Release of information will be subject to Mohegan Tribal laws including, but not limited to, the Mohegan Freedom of Information Ordinance found in the Mohegan Code of Laws, Part II, Chapter 1, Article VI.

APPENDIX D-4
Beneficiary Eligible Mitigation Action Certification

BENEFICIARY ELIGIBLE MITIGATION ACTION CERTIFICATION

Beneficiary Mohegan Tribe of Indians of Connecticut (MTIC)

Lead Agency Authorized to Act on Behalf of the Beneficiary **Mohegan Environmental Protection Department (MEPD)** *(Any authorized person with delegation of such authority to direct the Trustee delivered to the Trustee pursuant to a Delegation of Authority and Certificate of Incumbency)*

Action Title:	Shuttle Bus Replacement
Beneficiary's Project ID:	2017-01
Funding Request No.	<i>(sequential)</i> 2017-02
Request Type: (select one or more)	Reimbursement <input checked="" type="checkbox"/> <u>Advance</u> Other (specify): _____
Payment to be made to: (select one or more)	Beneficiary <input checked="" type="checkbox"/> Other (specify): Mohegan Tribal Gaming Authority
Funding Request & Direction (Attachment A)	<input checked="" type="checkbox"/> Attached to Certification <input type="checkbox"/> to be Provided Separately

SUMMARY

Eligible Mitigation Action	<input checked="" type="checkbox"/> Appendix D-2 item (specify): <u>Class 4-6 Shuttle or Transit Bus</u>
Action Type	Item 10 - DERA Option (5.2.12) (specify and attach DERA Proposal):
Detailed Description of Mitigation Action Item Including Community and Air Quality Benefits (5.2.2):	Replace one 2006 (Bus # 31) diesel transit bus with a new 2019 Ford F550 diesel, class 6 bus BUS #31 VIN # 1BAGNBXA76F239409 See 5.2.2 Addendum for details.
Estimate of Anticipated NOx Reductions (5.2.3):	1.08 short tons annually, or 6.477 tons for the lifetime of the project. See 5.2.3 Addendum for details.
Identification of Governmental Entity Responsible for Reviewing and Auditing Expenditures of Eligible Mitigation Action Funds to Ensure Compliance with Applicable Law (5.2.7.1):	Jean E. Mcinnis, Mohegan Environmental Protection Administrator. Mohegan Environmental Protection Department
Describe how the Beneficiary will make documentation publicly available (5.2.7.2):	Notices will be posted under a tab entitled "VW Settlement" on the public access website: https://mohegan.nsn.us/. See 5.2.7.2 Addendum for more details.
Describe any cost share requirement to be placed on each NOx source proposed to be mitigated (5.2.8):	Mohegan Transportation Department pays any overage to the allocated amount received as recipient of the 2019 Ford F550 replacement vehicle. Cost share is \$6983 which is 6%.
Describe how the Beneficiary complied with subparagraph 4.2.8, related to notice to U.S. Government Agencies (5.2.9):	Provided copies of the Trust Agreement with attachments to DOJ, DOA, USFWS, BIA, EPA & NAMC

If applicable, describe how the mitigation action will mitigate the impacts of NOx emissions on communities that have historically borne a disproportionate share of the adverse impacts of such emissions (5.2.10)

N/A

ATTACHMENTS
(CHECK BOX IF ATTACHED)

- Attachment A Funding Request and Direction.
- Attachment B Eligible Mitigation Action Management Plan Including Detailed Budget and Implementation and Expenditures Timeline (5.2.4).
- Attachment C Detailed Plan for Reporting on Eligible Mitigation Action Implementation (5.2.11).
- Attachment D Detailed cost estimates from selected or potential vendors for each proposed expenditure exceeding \$25,000 (5.2.6). [Attach only if project involves vendor expenditures exceeding \$25,000.]
- Attachment E DERA Option (5.2.12). [Attach only if using DERA option.]
- Attachment F Attachment specifying amount of requested funding to be debited against each beneficiary's allocation (5.2.13). [Attach only if this is a joint application involving multiple beneficiaries.]

CERTIFICATIONS

By submitting this application, the Lead Agency makes the following certifications:

1. This application is submitted on behalf of Beneficiary Mohegan Tribe of Indians of CT and the person executing this certification has authority to make this certification on behalf of the Lead Agency and Beneficiary, pursuant to the Certification for Beneficiary Status filed with the Court.
2. Beneficiary requests and directs that the Trustee make the payments described in this application and Attachment A to this Form.
3. This application contains all information and certifications required by Paragraph 5.2 of the Trust Agreement, and the Trustee may rely on this application, Attachment A, and related certifications in making disbursements of trust funds for the aforementioned Project ID.
4. Any vendors were or will be selected in accordance with a jurisdiction's public contracting law as applicable. (5.2.5)
5. Beneficiary will maintain and make publicly available all documentation submitted in

support of this funding request and all records supporting all expenditures of eligible mitigation action funds subject to applicable laws governing the publication of confidential business information and personally identifiable information. (5.2.7.2)

DATED: 4-4-19

Jean E. McInnis
Environmental Protection
Administrator

Michigan Environmental Protection
[LEAD AGENCY] Department

for

Michigan Tribe of Indians of
[BENEFICIARY]
Connecticut

[SAMPLE ATTACHMENT B - USE OF THIS FORMAT IS NOT MANDATORY]

**PROJECT MANAGEMENT PLAN
PROJECT SCHEDULE AND MILESTONES**

Milestone	Date
Lead Agency Provides Notice of Availability of Mitigation Action Funds	1-4-19
Project Sponsor Submits Proposal to Lead Agency	1-24-19
Lead Agency Provides Written Approval of Project Sponsor's Proposal	1-30-19
Lead Agency Incorporates Project Sponsor's Proposal into Mitigation Plan	1-31-19
Trustee Acknowledges Receipt of Project Certification and Funding Direction	4-30-19
Trustee Allocates Share of Funds for Approved Project	5-22-19
Lead Agency Directs Funding (Advance Funded Projects)	5-15-19
Project Sponsor Obtains Cost Share, Notifies or Certifies to Lead Agency	6-30-19
Project Sponsor Enters into Contracts, Purchase Orders, etc. - Start	6-15-19
Project Sponsor Enters into Contracts, Purchase Orders, etc. - Complete	7-15-19
Project Installation(s) - Start	N/A
Project Installation(s) - Complete	N/A
Project Sponsor provides detailed invoices for all claimed project costs, documentation for emission reduction estimates, required certification documents to Lead Agency to support direction to Trustee for Payment (Reimbursement, Direct-to-Vendor) or final accounting (Forward Funded Projects)	-
Lead Agency completes review and certifies payment direction to Trustee (Reimbursement)	N/A
Trustee Acknowledges Receipt of Direction for Payment(s) (Advance Funded, Reimbursement)	-
Project Sponsor Certifies Project Completion	7-31-19
Lead Agency Reports Project Completion	7-31-19

PROJECT BUDGET

Period of Performance: 1/2/19 – 7/31/19

Budget Category	Total Approved Budget	Share of Total Budget to be Funded by the Trust	Cost-Share, if applicable (Entity #1)	Cost-Share, if applicable (Entity #2)
1. Equipment Expenditure	\$ 123,263	\$ 116,280	\$ 6983	\$
2. Contractor Support <i>(Provide list of Approved Contractors as Attachment with approved funding ceilings)</i>	\$	\$	\$	\$
3. Subrecipient Support <i>(Provide list of Approved Subrecipients or Grant Awardees as Attachment with approved funding ceilings)</i>	\$	\$	\$	\$
4. Administrative ¹	\$	\$	\$	\$
Project Totals	\$ 123,263	\$ 116,280	\$ 6983	\$
Percentage	100%	94%	6%	%

¹ Subject to Appendix D-2 15% administrative cap.

PROJECTED TRUST ALLOCATIONS;

	2017	2018	2019	2020	2021
1. Anticipated Annual Project Funding Request to be paid through the Trust	\$	\$	\$ 116,280	\$	\$
2. Anticipated Annual Cost Share	\$	\$	\$ 6983	\$	\$
3. Anticipated Total Project Funding by Year (line 1 plus line 2)	\$	\$	\$ 123,262	\$	\$
4. Cumulative Trustee Payments Made to Date Against Cumulative Approved Beneficiary Allocation	\$	\$	\$ 0	\$	\$
5. Current Beneficiary Project Funding to be paid through the Trust (line 1)	\$	\$	\$ 0	\$	\$
6. Total Funding Allocated to for Beneficiary, inclusive of Current Action by Year (line 4 plus line 5)	\$	\$	\$ 0	\$	\$
7. Beneficiary Share of Estimated Funds Remaining in Trust	\$	\$	\$ 0	\$ 0	\$
8. Net Beneficiary Funds Remaining in Trust, net of cumulative Beneficiary Funding Actions (line 7 minus line 6)	\$	\$	\$ 0	\$	\$

ATTACHMENT C – REPORTING REQUIREMENTS

The Mohegan Tribe of Indians of Connecticut will for each Eligible Mitigation Action (EMA) no later than 6 months after receipt of the first disbursement of Trust Assets and thereafter no later than January 30 (for the preceding six month period of July 1 to December 31) and July 30 (for the preceding six month period of January 1 to June 30) of each year will submit to the Trustee a semi-annual report describing the progress implementing each EMA during the six month period leading up to the reporting date including a summary of all costs expended on the EMA through the reporting date. Such reports shall include a complete description of the status including actual or projected termination date, development, implementation and any modifications of each approved EMA. The reports will be signed by an official with authority to submit the report and will contain an attestation that the information is true and correct and that the submission is made under penalty of perjury.

5.2.2 ADDENDUM – DETAILED PLAN FOR REPORTING ON ELIGIBLE MITIGATION ACTION IMPLEMENTATION -

CLASS 4-8 SHUTTLE BUS REPLACEMENT

REPLACE- MENT YEAR	BUS # & MODEL YEAR	VIN # OF BUS TO BE REPLACED	ENGINE SERIAL # OF BUS TO BE REPLACED	EPA CERTIFICATES OF CONFORMITY	DATE NEW BUS PURCHASE	DATE OLD BUS SCRAPPED
2019	#31/2006	1BAGNBXA76F239409	46569898	NMHC+NOX = 2.9		

Notes: See attached picture of bus 31. EPA certificate of conformity for emission level (NMHC+NOX) listed above were obtained directly from the Cummins, Bluebird or International manufacturer, from the actual engine tag plate or from test data received from the manufacturer.

The replacement vehicle will serve as both a guest and an employee transport bus with a 19,500 GVWR, 6.7 liter diesel, Starcraft commercial 28 passenger capacity and will be maintained in accordance with manufacturer specifications.

When the original vehicle is retired, it will be rendered permanently disabled by drilling a 3” hole in the engine block and manifold and disabling the chassis by cutting it in half while in the MTGA Transportation Department possession as the acceptable scrapping method. Evidence of proper disposal will be provided with engine serial number, vehicle identification number of the bus scrapped along with the vehicle engine’s EPA certificate of conformity. The new vehicle engine’s certificate of conformity will be obtained from the engine manufacturer or from the emission control information label on the engine. This information will be recorded by MTGA Transportation.

5.2.3 ADDENDUM

Emission Results and Health Benefits for Project: Diesel Bus Replacement

Emission Results

Here are the combined results for all groups and upgrades entered for your project.¹

<u>Annual Results (short tons)²</u>	NO_x	PM2.5	HC	CO	CO₂	Fuel³
Baseline of Entire Project	1.324	0.050	0.155	0.492	159.3	14,164
Baseline for Upgraded Vehicles	1.202	0.049	0.143	0.455	90.2	8,014
Amount Reduced After Upgrades	1.080	0.048	0.132	0.417	28.1	2,500
Percent Reduced After Upgrades	81.5%	96.1%	85.1%	84.8%	17.7%	17.7%

Lifetime Results (short tons)²

Baseline of Entire Project	9.536	0.310	1.079	3.440	1,855.5	164,934
Baseline for Upgraded Vehicles	7.213	0.292	0.860	2.728	540.9	48,084
Amount Reduced After Upgrades	6.477	0.286	0.791	2.504	168.8	15,000
Percent Reduced After Upgrades	67.9%	92.2%	73.3%	72.8%	9.1%	9.1%

Lifetime Cost Effectiveness (\$/short ton reduced)

Capital Cost Effectiveness⁴ (unit & labor costs only)	\$19,184	\$434,481	\$157,119	\$49,620	\$736
Total Cost Effectiveness⁴ (includes all project costs)	\$19,030	\$430,985	\$155,855	\$49,221	\$730

¹ Emissions from the electrical grid are not included in the results.

² 1 short ton = 2000 lbs.

³ In gallons; fuels other than ULSD have been converted to ULSD-equivalent gallons.

⁴ Cost effectiveness estimates include only the costs which you have entered.

Remaining Life	Cummins: Transit Bus Transit Buses	0 years
	Ford 550: Transit Bus Transit Buses	19 years

Transit Shuttle Bus #31
VIN # 1BAGNBXA76F239409



ATTACHMENT D

1-23-19

██████████
Mohegan Sun Casino

Starcraft Commercial Bus F550 28 Passenger Diesel

Chassis:

2019 Ford F550

F550, 19,500 GVWR

Class 6 Vehicle

6.7 Liter Diesel

30.5 Foot bus

Front and Rear mud flaps

Dual alternators

OEM driver's seat w/armrest

Body Options:

LED interior and exterior lights

Grey rubber flooring

SS wheel covers

100,000 BTU a/c

(2) 65,000 BTU with Heater Booster Pump

Backup camera

Mid high seats with grabs and arms on aisle side

Seats are Level 5

Red lights over emergence exits

White standee line

Heated remote mirrors

MorRyde suspension

Retractable seatbelts

White standee line

Yellow step nosing

Raised floor

Heavy duty driver running board

Door activated interior lights

Am/fm/cd with mic

Electric entry door with exterior key

Right hand entry rail

Stanchion behind driver

Dual overhead grab rails

Front and side Transign Electronic

This is not a stock bus and will require a 20% deposit.

Your cost is \$117,397 per bus.
Less Ford rebate of \$3,000.

Total cost is \$114,397.00
PLUS CT TAX 8,865.77 (7.75%)
Total is \$123,262.77

Price includes all rebates (you will have to sign a letter from Ford saying you received the rebates in your pricing). The total does not include titling fees.



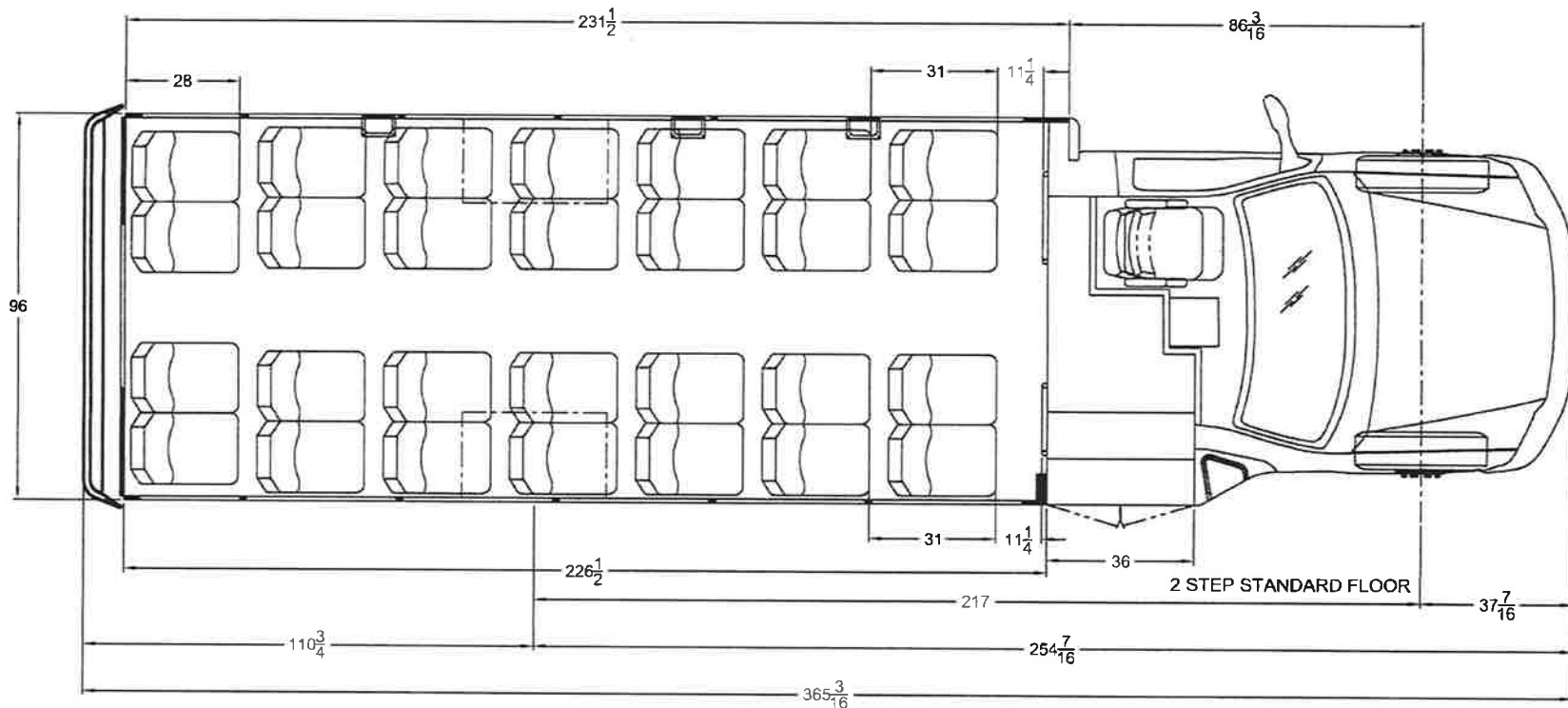

DEALER APPROVAL

APPROVED

CUSTOMER SIGNATURE

NOTE: SHOWN WITH MID HI FREEDMAN SEATS
 ALLSTAR XL F-550 19,500 GVWR
 THIS FLOOR PLAN IS FOR ILLUSTRATION PURPOSES ONLY.
 A WEIGHT ANALYSIS HAS NOT YET BEEN PERFORMED.
 FINAL APPROVAL WITH A WEIGHT ANALYSIS IS REQUIRED UPON RECEIPT OF A
 COMPLETED ORDER WITH ALL OPTIONS SHOWN
 OPTIONAL EQUIPMENT MAY BE SHOWN
 THE SALES ORDER PLACED DICTATES ACTUAL OPTION CONTENT.

**SCALE
IN INCHES**

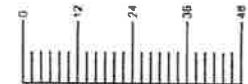

TOLERANCE UNLESS OTHERWISE SPECIFIED		STARCRAFT BUS a division of Forest River, Inc.	
WOOD	OTHER	DATE: 02/21/17	TITLE: 28 PASSENGER 217" WB 226 BDY 30 ALLSTAR XL
± 1/8"	± 1/16"	NAME: TAS	
± 1°	± 1/2°	DWG. No.	28 PASS 217 226 USA

THIS DRAWING AND THE INFORMATION THEREON ARE THE EXCLUSIVE PROPERTY OF STARCRAFT BUS, A DIVISION OF FOREST RIVER. IT SHALL NOT BE COPIED OR DUPLICATED IN ANY MANNER, NOR SHALL IT BE SUBMITTED TO OUTSIDE PARTIES FOR EXAMINATION WITHOUT OUR WRITTEN CONSENT. IT IS LOANED FOR USE WITH REFERENCE TO WORK UNDER CONTRACT WITH, OR PROPOSALS SUBMITTED TO STARCRAFT BUS, A DIVISION OF FOREST RIVER.

REV	LET	DESCRIPTION OF CHANGE	BY	CHK	DATE	ECN No
A		PRELIM PACKET:	TAS		02/21/17	

5.2.7.2 ADDENDUM

The Mohegan Tribe of Indians of Connecticut will establish a webpage on the publicly accessible website <https://mohegan.nsn.us/> dedicated to the funding received from the VW Settlement Trust, which will include a link for members of the public to request additional information and documents related to the funding request and expenditure of funds. The Mohegan Tribe of Indians of Connecticut will endeavor to respond to such requests within ten (10) business days and when documents are requested, will advise the individual within that timeframe of the procedure for reviewing documents.

The Mohegan Tribe of Indians follows the Mohegan Code of Laws including but, not limited to, the Mohegan Freedom of Information Ordinance found in the Mohegan Code of Laws, Part II, Chapter 1, Article VI for matters governing the publication of confidential business information and personally identifiable information and exemptions thereto.